

## STOVES IN BOATS

Some of the basics about fitting and using solid fuel stoves on boats in the UK and Ireland.

The numbers in (brackets) are sections in **British Standard BS 8511:2010 Code of practice for the installation of solid fuel heating and cooking appliances in small craft** where much more detailed information can be found. The code isn't compulsory, but will always be referred to if an accident occurs.

A good stove and its chimney will follow the rules here and:

- Be recommended by the manufacturer for use in boats.
- Be installed by a competent person. (5.2)
- ... strictly to the maker's instructions
- Be the right size for the space to be heated.
- Have securely latching doors which can't jolt open.
- Use very dry wood or smokeless fuels. Avoid bituminous coal (called 'housecoal' or 'Polish coal')
- Have chimney and flueways cleaned very regularly.
- Have door seals, windows and liners kept sound.
- If your stove has a lower ash door which can be opened separately from the main door – take *very great care*, leaving it open can make the fire burn far too fiercely, a common cause of serious boat fires.

- > Choose an insulated flue pipe to make the smoke rise
- > Make sure enough fresh air is coming in.
- > Keep anything flammable well away.

**STOVE SITED** where it won't cause obstruction, particularly to escape routes or near steps. (5.1)

**WELL AWAY FROM COMBUSTIBLES** ...anything like wood, GRP, fuel, gas containers, oil, candles, curtains, cushions, clothing, books, oil lamps, fold-away furnishings or anything which could create a fire hazard – all as far away as the stove maker says is safe, usually about **600mm away** or behind a **PROTECTION PANEL**. (5.1)

### Heat PROTECTION PANELS

Stoves and uninsulated flue pipes can easily get hot enough to set fire to paint, wood or other combustibles a distance away. A single fireproof panel fastened straight to a wall is no use – heat can pass straight through it.

One way of making a good protection panel is to have: a **10mm air gap** (supported on offcuts), then **25mm thick calcium silicate board** (which can be tiled) then at least a **45mm gap** to the stove body, all extending at least **200mm** above the stove. (7) (By the way, this construction can be used as the hearth underneath a stove with legs, if topped by a 15mm cement-board panel.)

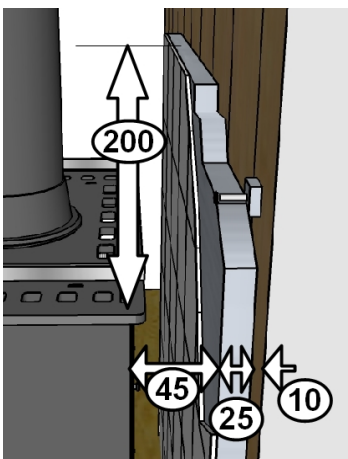

Open-sided **RAIN CAP** (8.4)

**HEIGHT** At least 600mm above the roof when moored – removable if need be. (8.4)

### INSULATED CHIMNEY

Insulated pipe outside *and* inside the cabin, for safety and to keep the smoke **HOT** so it rises. Uninsulated pipe cools the smoke down and drastically spoils stove performance. (8.2)

### THROUGH THE ROOF

The pipe should have provision for expansion, have no join inside the roofspace and be well protected from combustibles (8.4)

BS EN14604 Optical smoke alarm

**FIT ALARMS!** Carbon Monoxide in smoke is poisonous, and fire can start unnoticed.

BS EN50291 CO alarm

Stoves need **FRESH AIR** to burn safely. Have a completely open vent of **550mm<sup>2</sup>** (about 1" square) for each 1kW of stove output, preferably divided between vents at high and low level (9)

The whole chimney able to be **CLEANED** from end to end (8.5)

### A SOUND CHIMNEY

Even tiny leaks in the chimney can let air in, which cools the smoke, stops it rising, and risks poisonous CO gas leaking out.

Check with the makers, but insulated pipe often needs to be **3/4 of its diameter** away from unprotected combustibles (8.2)

**IDEALLY STRAIGHT**, but never more than 2 x 30° bends and **NO** horizontal lengths! (8)

If there has to be a short length of **uninsulated** pipe to connect to the insulated chimney, then **at least 3x its diameter** away from unprotected combustibles.

Stoves to the latest safety standards show an 'EN' number and how close combustibles can safely be.

(5.3) Stove, hearth and chimney all **FIXED FIRMLY IN PLACE**

### FLUE PIPES

fit socket end up, and are sealed with fire cement (8.3). They should be of the diameter recommended by the stove manufacturer, and never less than 100mm.

**THE HEARTH** needs to project at least 225mm in front and 150mm to each side of the stove **OR** have a high lip. Made of sturdy, non-flammable material, to fully protect combustibles underneath. (6)

